

200 Series Double Combination

ADR
Approved

100%
Water Proof

5 Year
Warranty

- Surface Mount
- Popular Design
- IP67 100% Waterproof
- ADR approved
- 5 Year Warranty

Function (Stop/Tail) (Indicator)
Size 200mm x 92mm x 28mm
Voltage 12-24 Volt
LED Qty 72
Cable 40cm cable

Draw	Stop	Tail	Ind
@13.8V	0.32A	0.04A	0.34A
@28V	0.18A	0.04A	0.19A

Approvals	Function	Category	CRN
ADR	Stop/Tail	49/00	35941
ADR	Indicator	6/00 2a	35795
CTA	Stop/Tail	49/00	CTA-060095
CTA	Indicator	6/00 2a	CTA-060095

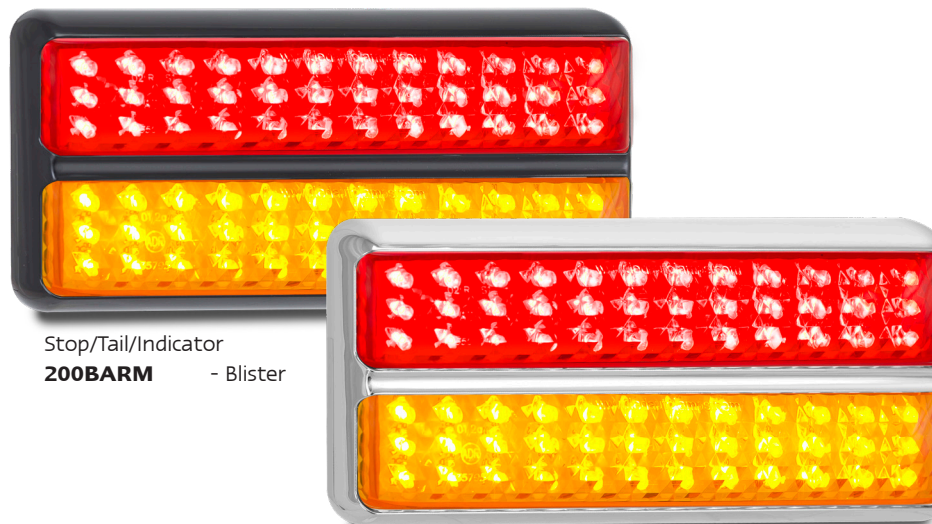

Stop/Tail/Indicator
200BARM - Blister

Stop/Tail/Indicator
200CARM - Blister

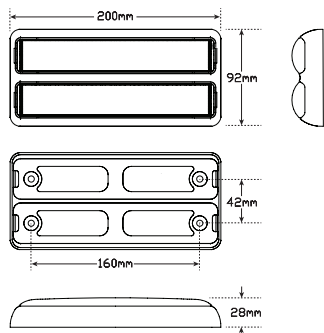

Fitting Instructions

Surface mount bracket onto flat surface horizontally with bolts provided, run wires through back and clip lens into place. Please refer to ADR 13/00.



All enquiries P: (03) 9466 7075 E: led@ledtech.com.au, www.ledautolamps.com

All efforts are made to ensure all information is correct and up to date, it can be subject to change without notice. All measurements are in millimeters (mm) and are not to scale.

© All LED Technologies designs are registered throughout the world. - Current as of 22/09/2020